

## APC730 Multi-function I/O

- **Analog Input**
- **Analog Output**
- **Digital I/O**
- **Counter/Timer**

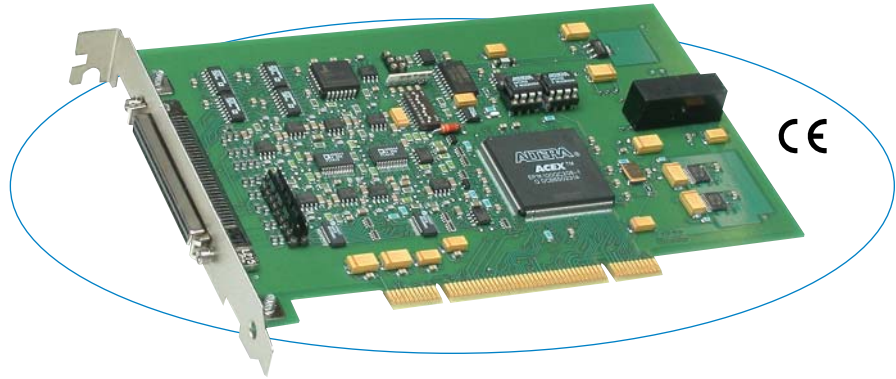

APC730 I/O boards provide a variety of I/O functions on a single card. These new high-density boards perform both high-speed and high-resolution A/D and D/A conversion and also handle digital I/O plus counter/timer functions.

Now you can conserve your precious card slots and still get all the I/O functionality you need. The APC730 is designed for extreme versatility with many deluxe features to meet most applications. However, the APC730 is still very budget-friendly.

### Features

#### Analog Inputs

- 16 differential or 32 single-ended inputs ( $\pm 3.3V$ ,  $\pm 5V$ ,  $\pm 10V$ ,  $0-5V$ , and  $0-10V$  ranges)
- 16-bit ADC with 512 sample RAM
- $10\mu S$  conversion time (100KHz)
- Interrupt upon ADC memory threshold condition (user-programmable data sample threshold)
- User-programmable interval timer

#### Analog Outputs

- Eight analog output channels ( $\pm 10V$  range)
- Individual 16-bit DACs per channel
- 1024 sample FIFO for waveform generation
- $12.375\mu S$  settling time (80.8KHz throughput)
- Interrupt on user-programmable FIFO threshold

#### Digital I/O

- 16 TTL bidirectional input/outputs

#### Counter/Timer

- One 32-bit counter/timer

#### Approvals

- CE marked, FCC Part 15, Class B

The APC730 combines analog I/O, digital I/O, and counter/timer functions on a single high-density module to save PCI slots.

### Specifications

#### Analog Input

Input configuration: 16 differential or 32 single-ended channels multiplexed to a single A/D converter.  
 A/D resolution: 16 bits.  
 Input ranges:  $\pm 3.3V$ ,  $\pm 5V$ ,  $\pm 10V$ ,  $0-5V$ , and  $0-10V$ .  
 Maximum throughput rate:  
 One channel updated at a time.  
 1 channel (maximum):  $10\mu S$   
 16 channels (maximum):  $160\mu S$   
 32 channels (maximum):  $320\mu S$   
 Data sample memory: 512 samples shared by all channels.  
 A/D trigger: Internal timer, external source, software.  
 On-board timer: One user-programmable timer for analog input acquisition control.  
 System accuracy:  $\pm 3$  LSB typ. (SW calib., gain=1,  $25^\circ C$ ).  
 Data format: Straight binary or binary two's complement.  
 Input overvoltage protection:  $-40$  to  $55V$  power off.  
 Common mode rejection ratio (60Hz): 96dB typical.  
 Channel-to-channel rejection ratio (60Hz): 96dB typical.

#### Analog Output

Output configuration: 8 single-ended channels, each controlled by its own independent D/A converter.  
 D/A resolution: 16 bits.  
 Output range:  $\pm 10V$ .  
 Maximum throughput rate:  
 Outputs updated simultaneously or individually.  
 1 channel:  $12.375\mu S$   
 8 different channels:  $12.375\mu S$   
 DAC programming: Via independent channel registers or through shared FIFO.  
 Data sample memory: 1024 sample FIFO shared by all channels.  
 D/A trigger: Internal timer, external source, software.  
 On-board timer: One user-programmable timer for analog output control.  
 System accuracy: 0.0076% of 20V span max. error corrected (i.e. calibrated) at  $25^\circ C$  with output unloaded.  
 Data format: Straight binary.  
 Output at reset: 0V.

Output current:  $-10$  to  $10mA$  (maximum).  
 Short circuit protection: Indefinite at  $25^\circ C$ .

#### Digital I/O

I/O channel configuration: 16 TTL transceivers, input/output direction selectable on an 8-channel basis.

#### Digital Input

Input voltage range: 0 to 5V DC.  
 Input signal threshold:  
 Low to high: 2.0V typical.  
 High to low: 0.8V typical.  
 Input response time: 250 nanoseconds.  
 Interrupts: 16 channels of interrupts for high-to-low, low-to-high, or any change-of-state event types.  
 Debounce: Individual debounce selectable on each channel. User-selectable ( $4\mu S$ ,  $64\mu S$ ,  $1mS$ , or  $8mS$ ).

#### Digital Output

Output voltage range: 0 to 5V DC.  
 Output ON current range:  $-15$  to  $64mA$ .  
 Output pullups: 4.7K ohm socketed resistors.

#### Counter/Timers

Counter/timer configuration: one 32-bit counter (requires use of channels 2 through 5 of digital I/O section).

#### Functions:

Watchdog timer, event counting, pulse measurement, period measurement, output waveform generation (pulse width modulation, continuous pulse, single pulse, continuous waveform).  
 Internal clock: Programmable 1, 4, 8MHz.  
 External clock: 3.4MHz.  
 Input voltage range: 0 to 5V DC.  
 Output voltage range: 0 to 5V with 4.7 ohm pull-up.  
 Maximum of 0 to 35V with external supply.

Continued on the next page.

## Block Diagram

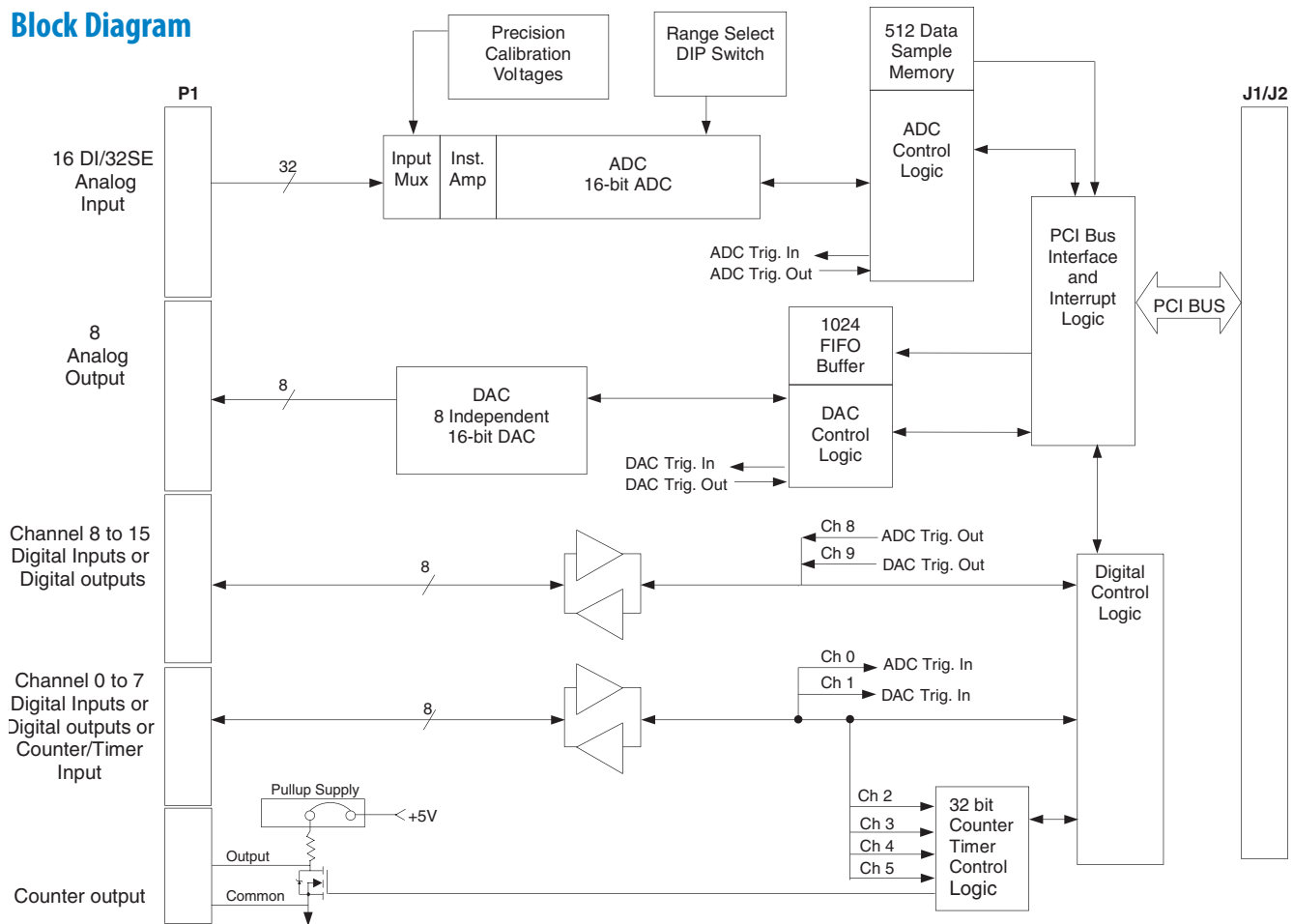

CompactPCI Boards

CompactPCI Boards

### Specifications (continued)

#### PCI Bus Compliance

This device meets or exceeds all written PCI local bus specifications per rev. 2.2 dated June 1998.

System base address: This board operates in memory space. It consumes 1K of memory space.

Data transfer bus: Slave with 32, 16, and 8-bit data transfer operation. 32-bit read or write accesses implemented as two 16-bit transfers.

Interrupts (INTA#): Interrupt A is used to request an interrupt.

#### Environmental

Operating temperature: 0 to 70°C  
(E version -40 to 85°C)

Storage temperature: -40 to 85°C.

Relative humidity: 5 to 95% non-condensing.

Power: 245mA at +5V (290mA maximum).

MTBF: Consult factory.

### Ordering Information

#### I/O Boards

##### APC730

Multi-function I/O board

##### APC730E

Same as APC730 plus extended temperature range

#### Software

**PMCSW-API-VXW:** VxWorks® software support package

**PCISW-API-WIN32:** 32-bit Windows® DLL Driver software package

**PCISW-API-WIN64:** 64-bit Windows® DLL Driver software package

**PCISW-LINUX:** Linux® support (website download only)

#### Accessories

##### 5025-288

Termination panel, SCSI-3 connector, 68 screw terminals

##### 5028-432

Cable, shielded, SCSI-3 connector at both ends

[Visit our web page for more information](#)

All trademarks are the property of their respective owners.